

Energy and Global Warming

Heading Toward Mid- to Long-Term Energy Conservation and Reductions in CO₂ Emission Volume

Basic Policy

Energy and global warming are the most pressing issues of the earth's environment. Climate change is a concern with its deep impact on the ecology and living environment for humans.

From the viewpoint of energy conservation, the Toyota Auto Body Group is actively moving forward with efforts to decrease CO₂ emissions. Working with Toyota Motor Corporation, our design and development departments are looking to improve vehicle fuel efficiency through our commitment to developing and introducing weight reduction technology in vehicle body steel sheets and vehicle interior materials.

In addition, our production and logistics departments are changing to clean energy through cumulatively improving and introducing energy conserving production technology in looking to have "Eco factories" that establish targets of a global management system and reductions in CO₂ emission volume. We are promoting efforts in all stages of vehicle design and development through production.

Action Items

Development and Design

- Commercialization and development of weight reduction technology that contributes to improved vehicle fuel efficiency

Production and Logistics

- Active promotion of measures to reduce CO₂

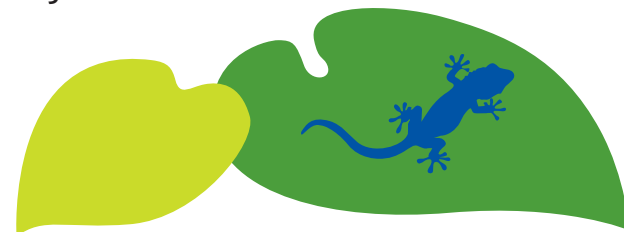

Activity Status

Development and Design

Commercialization and Development of Weight Reduction Technology That Contributes to Improved Vehicle Fuel Efficiency

In conjunction with new-model and full-model changes, we are able to progress more easily toward improved fuel efficiency through being supplied with fuel efficient engines supplied by Toyota, the introduction of more efficient transmissions, and also Toyota Auto Body's commercialization and development of vehicle body and interior weight reduction technology.

■ Vehicle Body Weight Reduction by Using High-Strength Steel Sheets and Aluminum Materials

Many extra high-strength steel sheets and high-strength steel sheets in exterior panels in the vehicle body frame of the new model Prius achieve a rigid body of reduced weight that offers reduced vibration and noise while also ensuring collision and operational safety. Use of aluminum for exterior panels achieves further weight reduction.

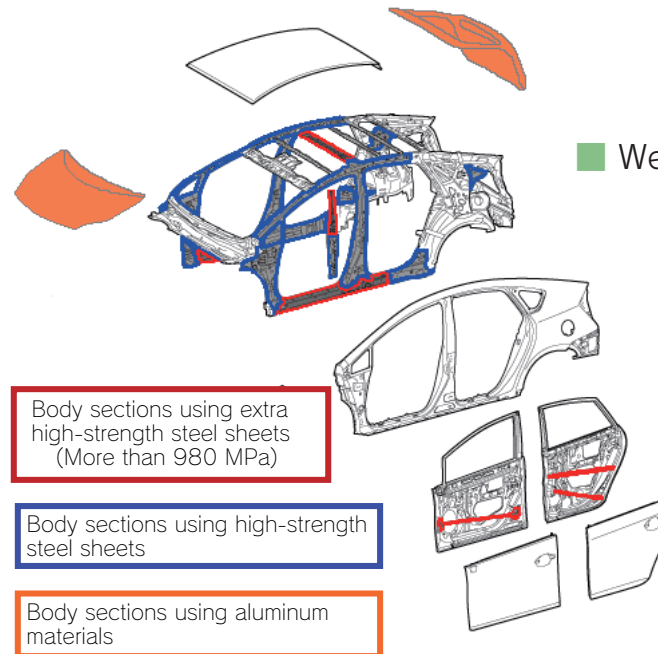

■ Weight per vehicle body (cabin frame)

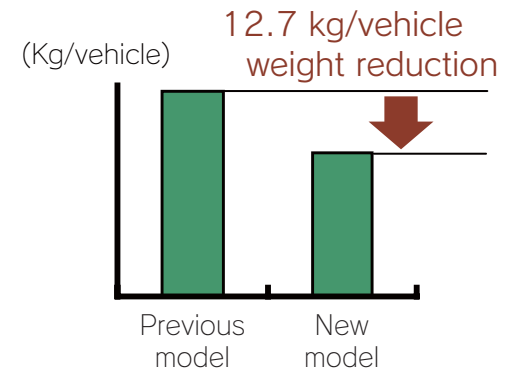

Activity Status

Development and Design

Commercialization and Development of Weight Reduction Technology That Contributes to Improved Vehicle Fuel Efficiency

■ Weight Reduction Achieved by Interior Materials and Reassessment of Structural Methods

We achieved weight reduction in the new model Prius by using a foam type material in the rear door trim board and front door trim board. Weight reduction was also achieved by using foam PP beads* in the deck floor box and we used an integrated-type honeycomb-structure deck board.

※: Foam PP beads: Polypropylene expanded 30 times

■ Door Trim weight per vehicle

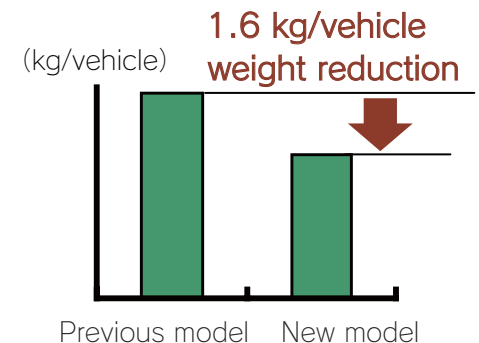
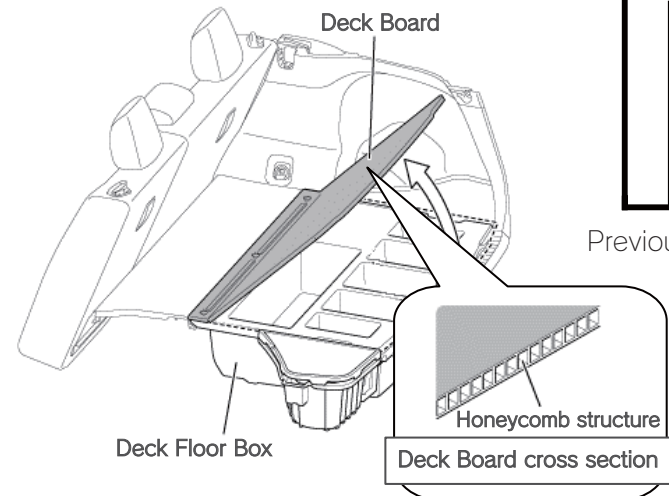
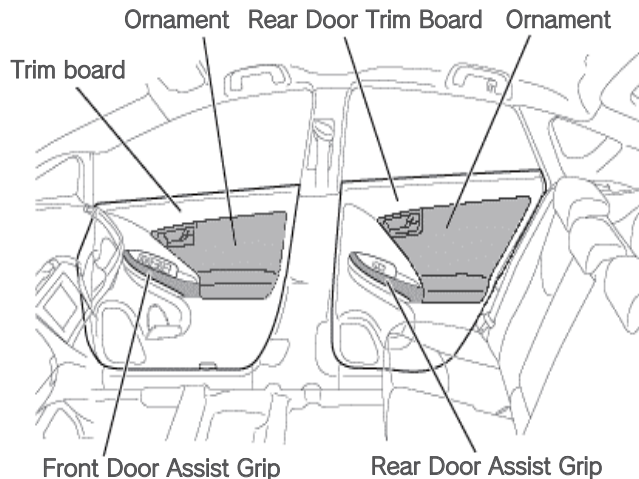

Activity Status

Production and Logistics

Active Promotion of Measures to Reduce CO₂

Reduce CO₂ Emission Volume From Fixed Sources of Release (1/2)

We at Toyota Auto Body are actively promoting the introduction of new technology and transitioning toward clean energy by using Natural gas(publicly supplied) as part of our activities to reduce CO₂. In particular, in the extremely tough economic conditions at the end of FY2008, all of our employees united in making energy conservation efforts such as production line summarization for more efficient production and decreasing energy losses during days production plants are closed and for periods of non-operation.

FY2008 Case Examples of Energy Conservation

Plant	CO ₂ reduction measure	Reduced volume (Thousand tons)
Yoshiwara	Introduced efficient turbo freezer	0.6
fujimatsu	Product line summarization (Stop operation of sealer drying oven)	1.0
inabe	Decrease air leaks in welding processes	0.2



Energy conservation by using a heat emitting winter highly efficient turbo freezer

In the winter, by efficiently using a heat emitting air compressor that previously emitted heat into the atmosphere, we made warm water with a heat pump type freezer and used it to heat our production plants.

[Highly efficient turbo freezer]



Comparison of Production Process Volume of Energy Heat (FY2008)

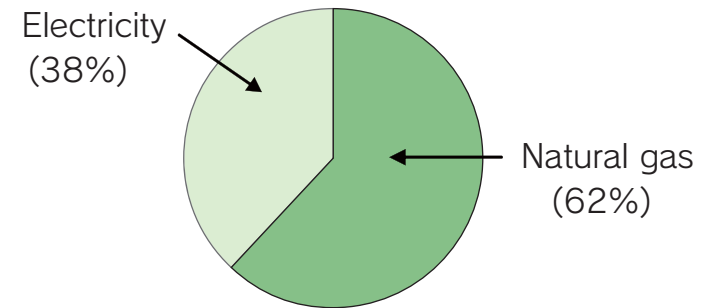

Activity Status

Production and Logistics

Active Promotion of Measures to Reduce CO₂

Reduce CO₂ Emission Volume From Fixed Sources of Release (2/2)

In FY2008, results were achieved from measures on the previous page, and with a reduction in the number of vehicles produced in the last half of the fiscal year, total emission were 191,000 tons-CO₂, and comparing FY1990 levels to the 2010 target of an increase of 5%, actual performance was achieved with an increase of 2%. Also, with regard to emissions per total sales unit, results came to 141 tons-CO₂ per billion yen, and a FY2003 10% decrease compared to the FY2010 target, we achieved a decrease of 32%.

Hereafter as well, in addition to introducing energy conserving equipment when reforming the factory, we are promoting the introduction of CO₂ reducing production technology and reductions in CO₂ emissions volume.

CO₂ emissions volume in production processes
 [FY2010 target : Less than 196,000 tons-CO₂] · · · ※ 1
 (5% increase compared to FY1990)

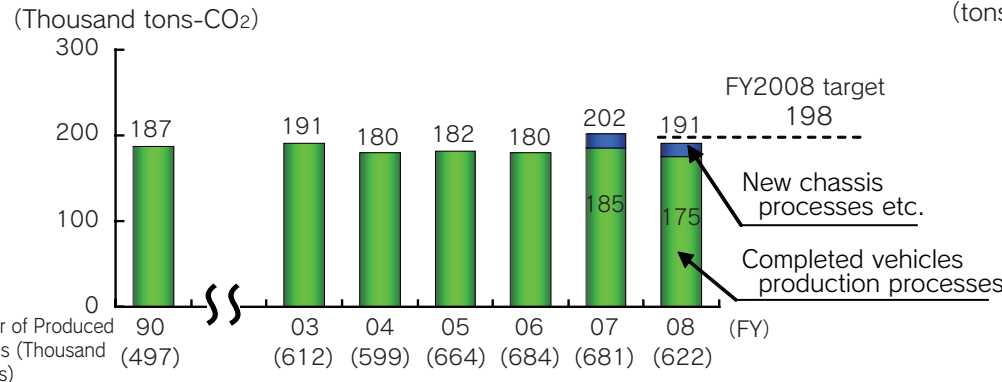

CO₂ emissions volume per sales unit
 [FY2010 target: Less than 185 tons-CO₂ per billion yen] · · · ※ 2
 (10% decrease compared to FY2003)

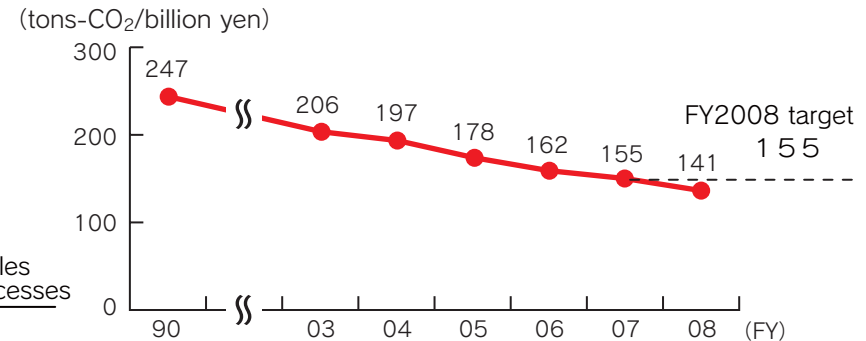

- ※ 1 CO₂ emissions volume : From the previous completed vehicle production process target (10% decrease compared to FY1990), we changed to a target that introduces all production processes such as the chassis newly equipped process from Toyota Motor Corporation (Less than 5% compared to FY1990). In FY2008, in the processes previously covering complete vehicle production process, despite a 25% increase in vehicles produced compared to FY1990 (622,000 vehicles produced by Toyota Auto Body on a unconsolidated basis), CO₂ emissions volume decreased by 6% (175,000 tons-CO₂).
- ※ 2 CO₂ emissions volume : We are promoting efforts to reduce emissions and we set a CO₂ emissions volume target that combines volumes for production processes and per sales unit

Activity Status

Production and Logistics

Active Promotion of Measures to Reduce CO₂

Reduction of Global CO₂ Emissions Volume From Production

Although we pushed forward with a target to reduce CO₂ emission volume per sales unit by FY2010 by 8% compared to FY2003, we achieved this target early. Hereafter, we will continue improving mutually introducing case examples of energy conservation by coordinating with 10 domestic and foreign consolidated companies

Global CO₂ Emissions Volume Per Sales Unit
 [FY2010 target: Less than 204 tons-CO₂/billion yen]
 (8% decrease compared to FY2003)

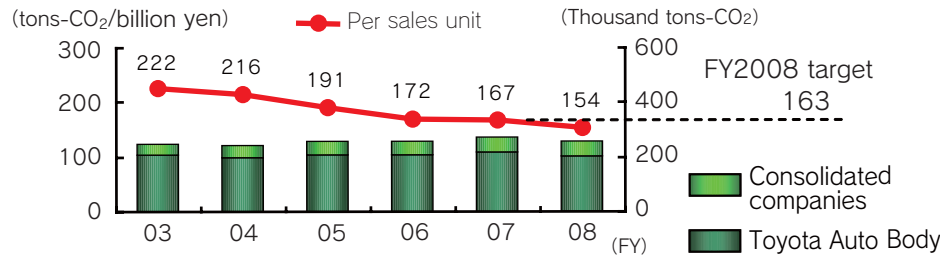

Switching to natural gas for boiler fuel at PT. Sugity Creatives in Indonesia.

Sugity Creatives switched to use natural gas instead of diesel, which was previously used for boiler fuel for painting bumpers. As a result, CO₂ emissions volume was reduced by 110 tons-CO₂ per year.



[Small type boiler for painting bumpers]

Reducing CO₂ Emissions Volume in Logistics

At Toyota Auto Body, we are actively moving toward electrifying plant tow vehicles and improving loading capacity of transport between plants (See map to the right). In looking to make production efficient within the Toyota Group, we at Toyota Auto Body are working to improve capacity efficiency from the shipping planning stage in order to transport mutual supplied parts shared for the same vehicle being made at other companies.

Logistics CO₂ emissions volume
 [FY2010 target: Less than 8,000 tons-CO₂]
 (10% decrease compared to FY2003)

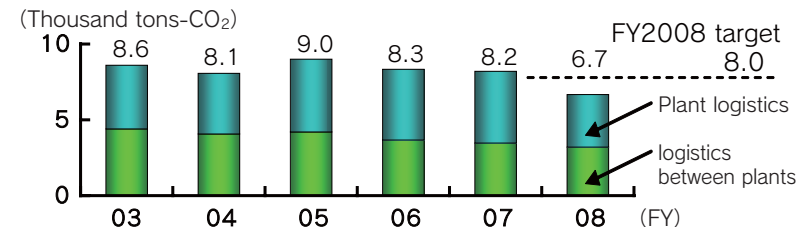

■ Topics

■ Thai Auto Works (Thailand) Won the Energy Award 2008

On July 31st 2008, President Ōno[※] of Thai Auto Works (Thailand), one of our group companies, was selected for the “Best Energy Top Management” award at the Thai Energy Awards 2008.

※Toyota Auto Body's Executive Corporate Officer as of July 2009

[President Ōno (Left) receiving the award from the Thailand Energy Minister]



■ Roof Greenification of Toyota Body Seiko Co., Ltd. New Toyohashi plant

At a group company, Toyota Body Seiko Co.,Ltd. Toyohashi Plant, in May of 2009, we promoted energy conservation by allowing in natural light which decreased electrical power use during the day. We also planted lawns on the roof of the No.2 factory building.



[Greenification of the Toyohashi No.2 plant building roof]

[The interior of the No.2 plant brightened by natural light]